



Connection of a Regional Broadband Consortium or Local Education Authority Network to the JANET Interconnect Service

Applicability

1. The JANET Interconnect Service is available to Regional Broadband Consortia (RBCs) and to those Local Education Authorities (LEAs) which have “opted out” from their respective RBCs. For brevity, the RBC or LEA network to be connected to the Interconnect Service is simply referred to as the “RBC Network” throughout this document. Apart from the bandwidth of the interconnection, the functional, technical and operational characteristics of the connection are identical whether it is a RBC network or LEA network that is to be connected.

Service Model

2. The Interconnect Service will provide an IP-level interconnection between each RBC Network and every other RBC Network subscribing to the Interconnect Service. It will also provide connectivity to all organisations connected to JANET. Transit from a RBC Network to the wider Internet will **not** be provided.
3. The Interconnect Service will be implemented on the SuperJANET backbone network. This is operated as a single IP network and to conventional Internet standards. The Interconnect Service will be part of this IP network and not a separate VPN. The standards and conventions of the SuperJANET backbone will need to be adhered to by a connecting RBC Network.
4. The key consequence of this is that only IP traffic with public addresses will be routed. It will be the responsibility of the operator of the RBC Network to provide and maintain suitable public IP addressing for those entities within the RBC Network which are to be accessible via the Interconnect Service.
5. Routing between the SuperJANET backbone and a RBC Network will be implemented via a BGP peering between a router on the SuperJANET backbone and a border router within the RBC Network’s management domain. All routing within the RBC Network and to its external connections will remain the responsibility of the operator of the RBC Network.
6. Only one BGP peering will be offered to an individual RBC Network (A back-up peering for resilience purposes will be offered, if requested.) It will be the responsibility of RBC management to agree with its contractors which will take on the above responsibility. UKERNA’s Network Operations Service Centre (NOSC) will deal only with the single contractor selected by the RBC and notified to UKERNA.
7. Further details of connection, IP addressing and routing issues are given in the rest of this document.

Physical Connection

8. The model for physical connection to the Interconnect Service is as follows:

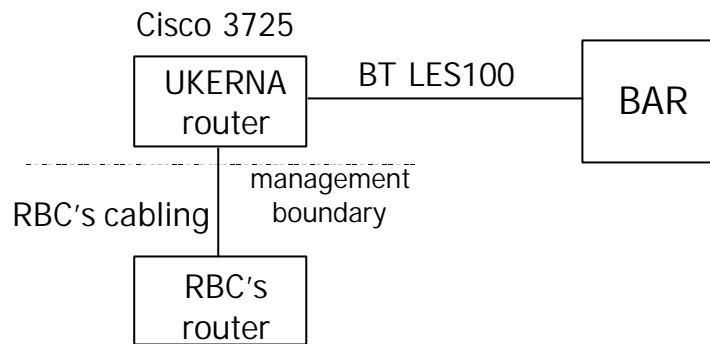

- (Note: the “BAR” is the “Backbone Access Router” operated by UKERNA at the SuperJANET Point of Presence used for access to the Interconnect Service. In the case of a LEA network the link between the BAR and the UKERNA router will be implemented by either a BT LES 10 link or two parallel MegaStream 2 links, dependant on distance.)
9. There are three RBC Networks which have chosen to present at Telehouse North in London (LGfL, SEGfL and SWGfL). These networks will be connected directly to a UKERNA PoP router at Telehouse North, rather than to individual 3725 routers. The connection will be a local Fast Ethernet and the paragraphs below relating to the 3725 and LES100 circuit will not be relevant to these connections.
10. The 3725 will need to be racked and powered by the operator of the RBC Network and at premises chosen by the RBC or its network operator. Access will also need to be made available to UKERNA’s engineers, and to the engineers of UKERNA’s hardware maintenance contractor. UKERNA expects that details of access arrangements to be agreed on an individual basis with each operator. It is preferable that full 24×7 access is available.
11. The physical dimensions and power requirements of the 3725 are:
- | | |
|-------------|---|
| dimensions: | 17.1 inch wide × 14.7 inch deep × 3.5 inch high |
| weight: | ca. 15 lbs |
| power: | single 13 amp AC. |
- The router is supplied with a 19 inch rack mounting kit.
12. An ISDN connection to the console port of the 3725 will also be required to allow remote access by UKERNA’s engineers. UKERNA will agree with the operator by which party this connection is provided. If provided by UKERNA the cost of provision will be an additional charge to the RBC or LEA.
13. The circuit from the SuperJANET BAR will be delivered into the premises at which the 3725 is to be housed, and as near as possible to the 3725 itself. Again, UKERNA expects to discuss on an individual basis the means most convenient to the operator by which the attachment of the circuit to the 3725 is made and maintained.
14. The Interconnect Service will be presented as a single RJ45 Fast Ethernet port on the 3725 router. It will be the responsibility of the operator of the RBC Network to provide the cabling required to attach to the 3725. For those RBC Networks presenting in Telehouse North, the presentation on the UKERNA PoP router will also be a single RJ45 Fast Ethernet port. The operator will be responsible for arranging cabling from its equipment to UKERNA’s rack. The rack location is:

Room: TFM1
Rack: 1E3

15. The logical connection between the 3725 and the RBC router will be a point-to-point IP connection. UKERNA will provide a /30 address prefix for this purpose, or other prefix as appropriate. The same arrangement will apply to connections in Telehouse North, between the UKERNA PoP and RBC routers.

IP Addressing

16. The SuperJANET backbone will route only those IP network numbers and prefixes that are publicly registered in the RIPE database. These may be from the address space used by the operator of the RBC Network, or may be provider independent network number ranges obtained by the RBC. UKERNA asks that the address ranges used are as contiguous as possible, so that it can aggregate routes as much as possible within the SuperJANET backbone.
17. If necessary the JANET IP Registry will provide an address range to a RBC, provided that there is a reason why either of the above options is inappropriate. However, this range will not be available for use by the operator of the RBC Network for any other purpose than to route traffic onto the Interconnect Service. The amount of any address space allocated by the JANET IP Registry will be governed by the rules maintained by the RIPE NCC—essentially that the allocation will be determined by the cases made for present need and future growth.

IP Routing

18. The border router nominated by the operator of the RBC Network will need to peer with a SuperJANET backbone router using the BGP4 protocol. The routes passed by the SuperJANET backbone across this peering will be those in AS786 (the JANET Autonomous System), plus those the backbone has accepted from each other RBC Network with which it is peering. At present AS786 contains approximately 185 prefixes. This number is not anticipated to change significantly as a high degree of route aggregation is practised. Therefore the memory requirements for the border router will be modest.
19. The SuperJANET backbone will accept from a RBC Network only those routes which have previously been registered with UKERNA. All other routes will be discarded. Initial registration of the network prefixes to be routed can be achieved via the “JANET Interconnect Service Request” form that will be sent to each RBC upon receipt by UKERNA of the RBC’s order for the Interconnect Service.
20. The operator of the RBC Network is free to implement its own filtering policy on the routes it receives from the SuperJANET backbone. However UKERNA recommends that it accepts all routes. This will obviate the need for a manual update system to notify the operator as and when another RBC Network registers and advertises new or amended routes.
21. The operator of the RBC Network is required to ensure that the preferred route for traffic between this network and all other RBC Networks is via the Interconnect Service. It may choose to allow traffic to fall back to its ISP connection, should the Interconnect Service route fail. UKERNA’s own policy for routing traffic from JANET sites to the RBC Networks will be to prefer the Interconnect Service, and it is strongly recommended that the operator adopts the same preference from traffic back to JANET sites.

Individual LEA Connections to JANET

22. Under existing JANET connection policy UKERNA makes available to any LEA a tariffed standard connection to JANET and the Internet as a whole. This is not widely taken up, but if a LEA within a RBC decides to take a JANET connection (i.e. it effectively chooses UKERNA as its

ISP) this will be its single route to the Interconnect Service. Address prefixes from entities within that LEA will not be accepted via the RBC's connection to the Interconnect Service.

DNS

23. Where an entity within a RBC Network is to be publicly addressable it should be registered in the public DNS. UKERNA will not be providing any form of private DNS server or zone files for the Interconnect Service.

Security Considerations

24. Although regulated via Acceptable Use and Security policies, JANET is a very large network with no policing beyond UKERNA's statutory obligations of the nature of the content which it transports. Therefore it is recommended that for practical purposes JANET is treated by the operator of the RBC Network as posing a similar level of threat to security as is present from the Internet as a whole.
25. For this reason traffic from the Interconnect Service should be filtered through any firewall that the RBC operates towards the external world. It is recommended that the router which terminates the physical connection to the Interconnect Service lies outside this firewall.
26. If the BGP peering is to be terminated on a border router inside the firewall it needs to be remembered that the firewall must allow the peering connection through.

Contacts for Further Information

27. Enquiries of a technical nature should be made to:
Tony Hacche
JANET Network Operations Service Centre (NOSC)
☎: (0207) 692 1440
✉: agh@nosc.ja.net
28. All other enquires should be made to:
Kate Nunn-Price
RBC Project Co-ordinator
☎: (01235) 822 220
✉: K.Nunn-Price@ukerna.ac.uk

Technical Meetings with UKERNA

29. UKERNA would welcome the opportunity to hold a technical meeting with the operator of the RBC Network to clarify and agree matters associated with the connection to the Interconnect Service. To arrange a meeting please contact Kate Nunn-Price, details as above.